

max. Abmessungen / max. Dimensions
1455 x 1165 x 1390

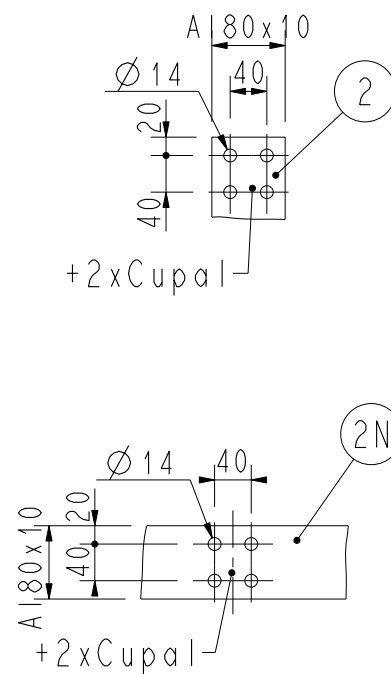
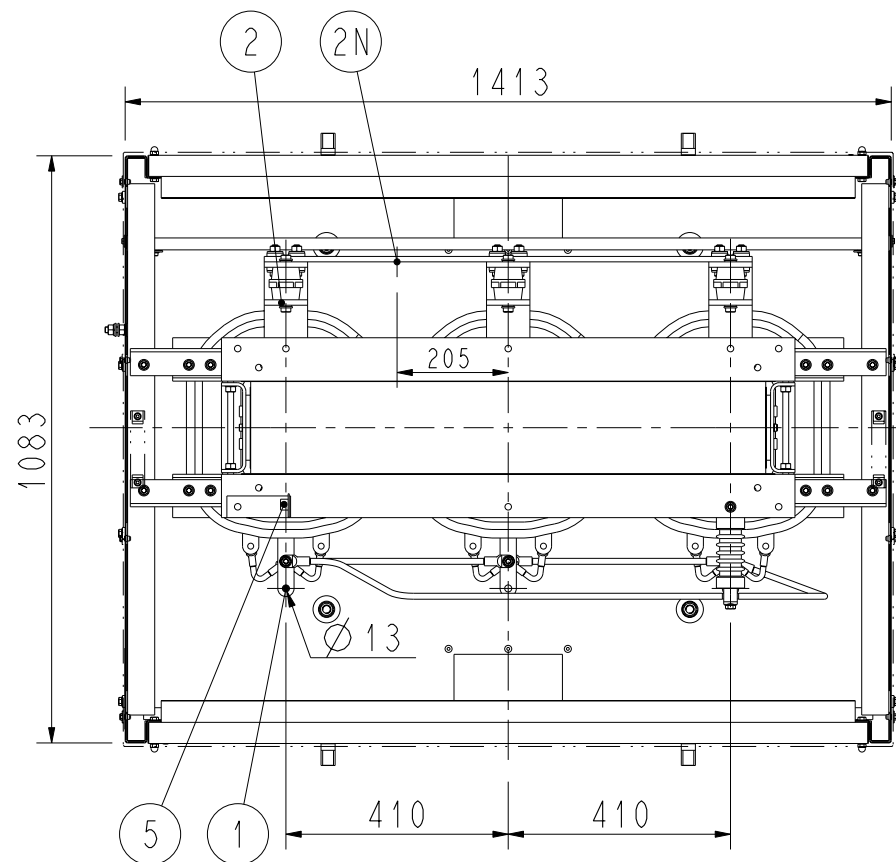
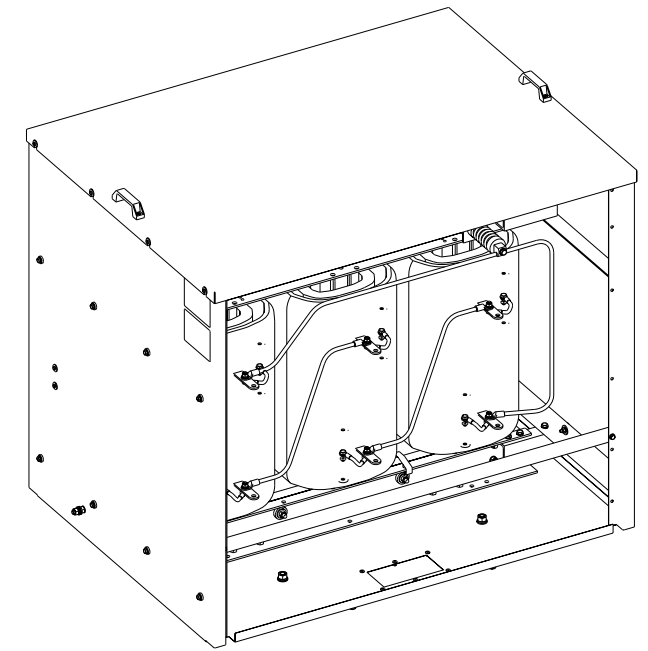
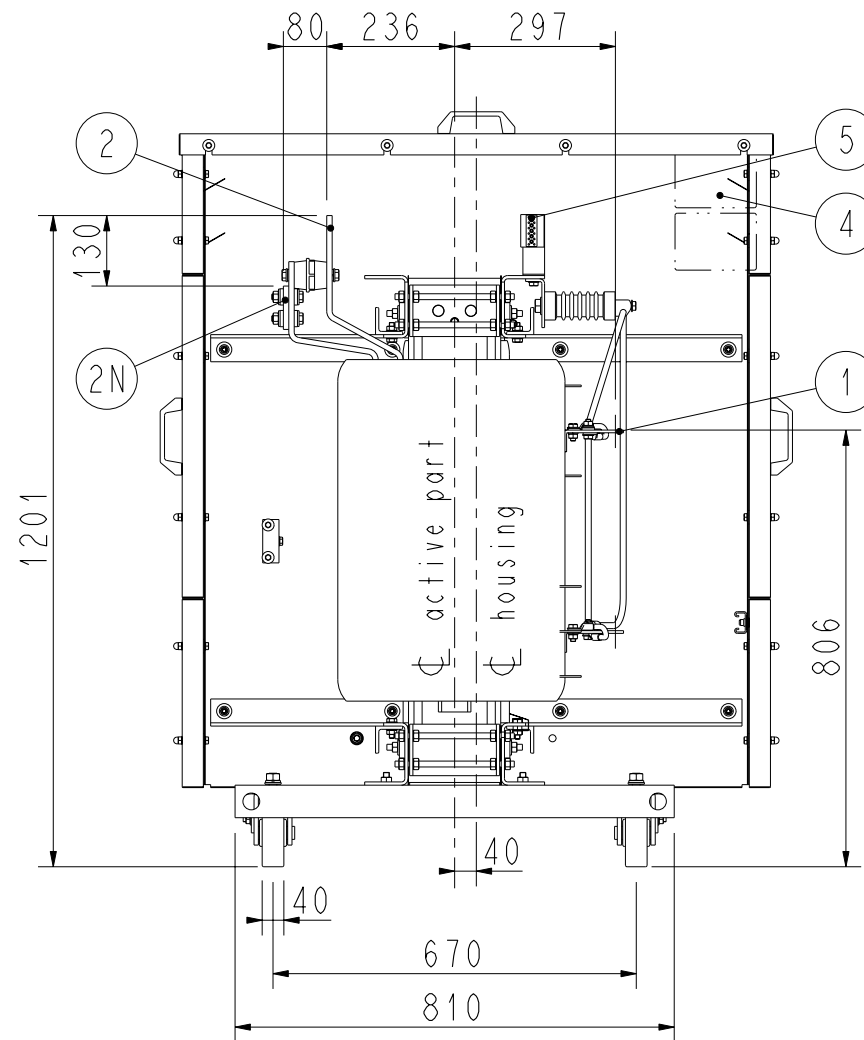
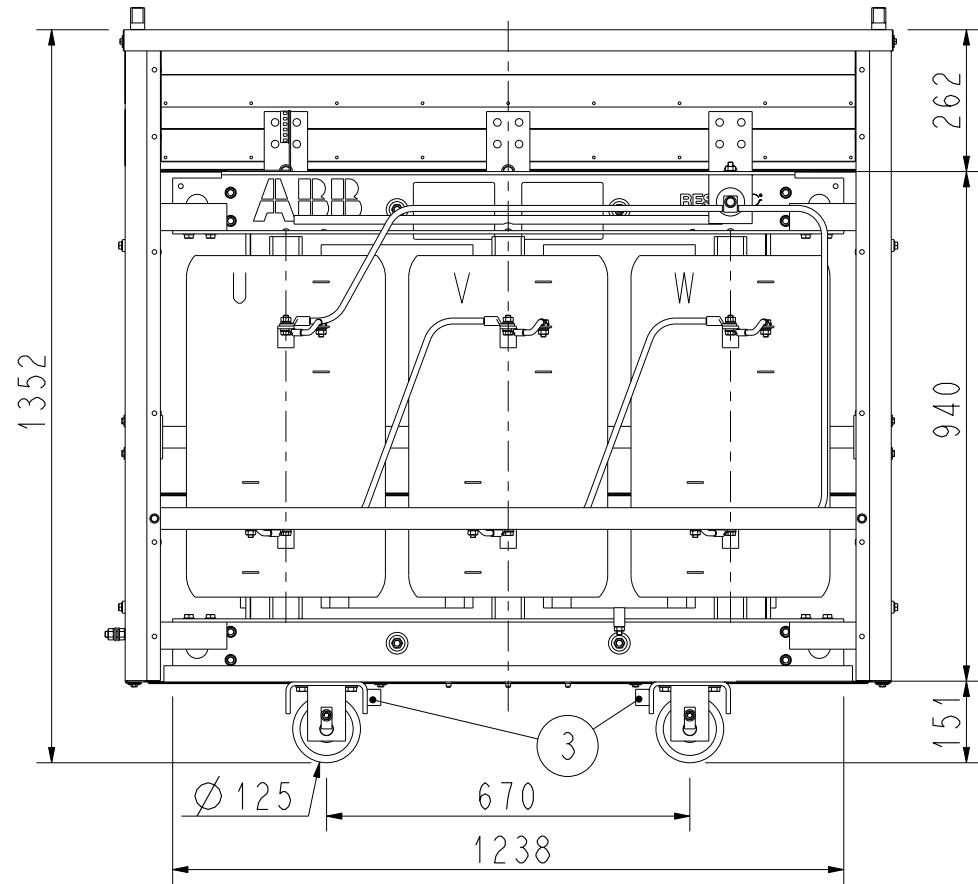

1	OS Anschluss / HV connection
2	US Anschluss / LV connection
2N	US Sternpunkt / LV starpoint
3	Erdung M12 / Earthing M12
4	Leistungsschild / Rating plate
5	Klemmleiste / PTC-Terminal

3-Phasen Trockentransformator / 3-Phase Dry-Type Transformer
Typ / Type RESIBLOC

Leistung / Rated power	[kVA]	315
Spannung OS / Rated voltage HV	[V]	10000 ±2x2.5%
Spannung US / Rated voltage LV	[V]	400
Schaltgruppe / Vector group		Dyn5
Schutzart / Protection mode		IP23
Frequenz / Frequency	[Hz]	50
Isol.Klasse / Insulation class		F
Gesamtgewicht / Total weight	[kg]	1290

RevInd	Revision	Appd	Date
Prepared	Date	Responsible department	Title
Approved	Date	Take over Department	
ABB Transformatoren GmbH			File: <auftrag>\trafo\massbild.drw Massbild Customer drawing Document No. 315/10023/12
			Language de Sheet 1/1