

Tmax

DOC. N.° RH0011805 - L2709

FC CuAl est. - Terminali esterni per cavi T1-T2-T3.
 FC CuAl ext. - External terminals for cables T1-T2-T3.
 FC CuAl ext. - Externe Anschlüsse für Kabel T1-T2-T3.
 FC CuAl ext. - Prises extérieures pour câbles T1-T2-T3.
 FC CuAl ext. - Terminales exteriores para cables T1-T2-T3.

	T1 III	T1 IV	T2 III	T2 IV	T3 III	T3 IV		T1 III	T1 IV	T2 III	T2 IV	T3 III	T3 IV
	3 (6)	4 (8)	-	-	-	-		-	-	2 (4)	2 (4)	2 (4)	2 (4)
	3 (6)	4 (8)	-	-	-	-		-	-	-	-	3 (6)	4 (8)
	1 (2)	1 (2)	-	-	-	-		-	-	-	-	1 (2)	1 (2)
	-	-	3 (6)	4 (8)	-	-		-	-	-	-	-	-
	-	-	3 (6)	4 (8)	-	-		-	-	-	-	1 (2)	1 (2)
	-	-	1 (2)	1 (2)	-	-		3 (6)	4 (8)	-	-	-	-
	-	-	1 (2)	1 (2)	-	-		3 (6)	4 (8)	-	-	-	-
	-	-	-	-	-	-		1 (2)	1 (2)	-	-	-	-

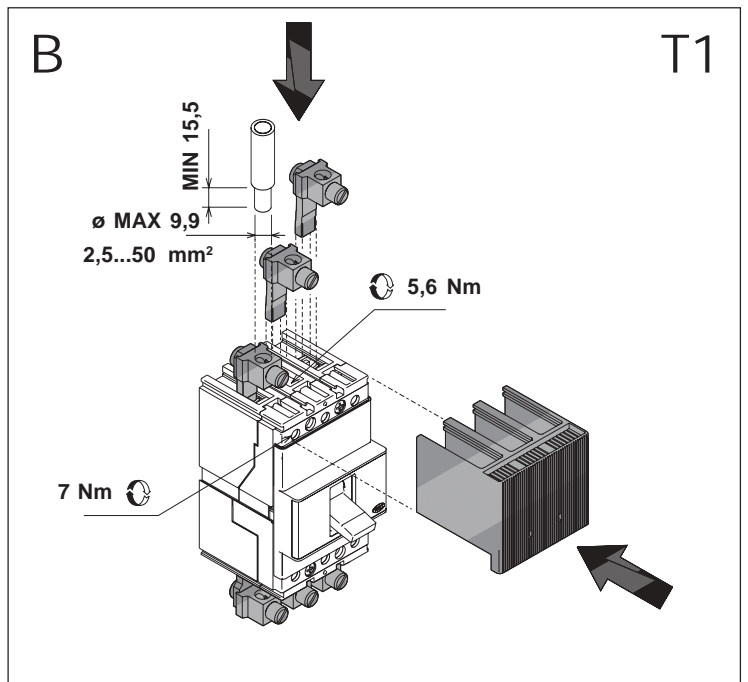
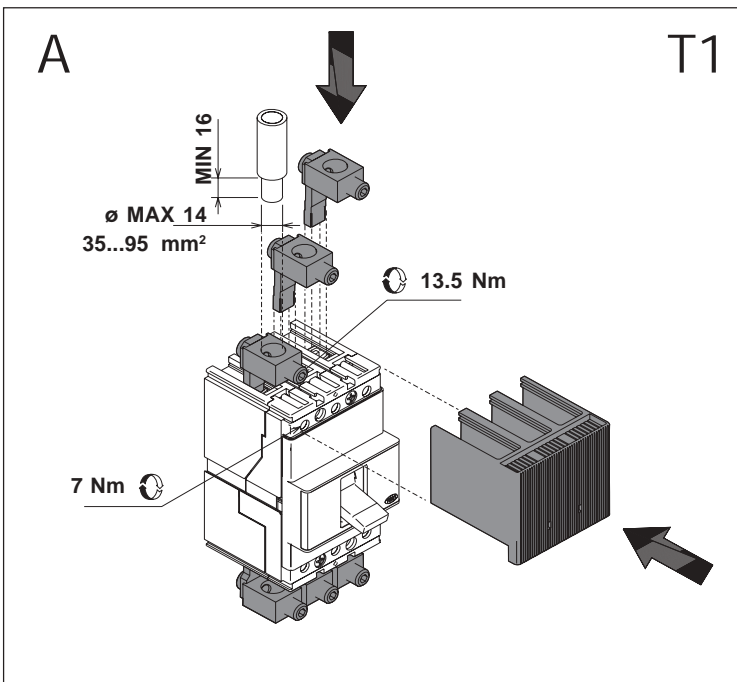

C

T2-T3

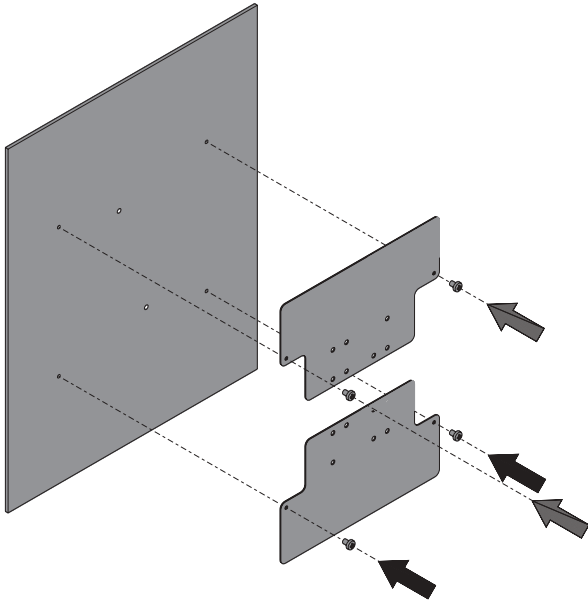

D

T2-T3

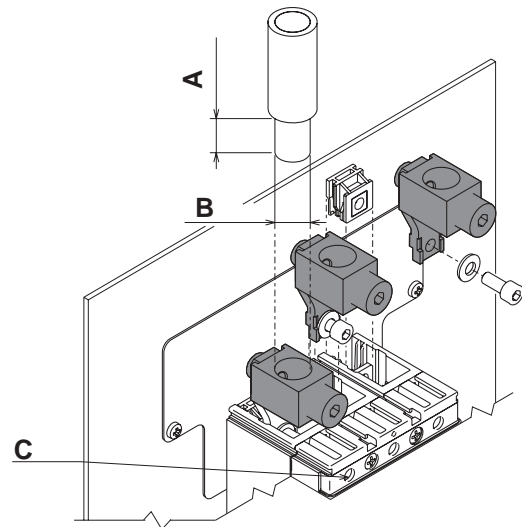

Cu/Al



	A Min mm	B Max mm	Sez. mm ²	C Nm
T2	22	18	185-70	6
T3	29	24	240-150	8

E

T2-T3

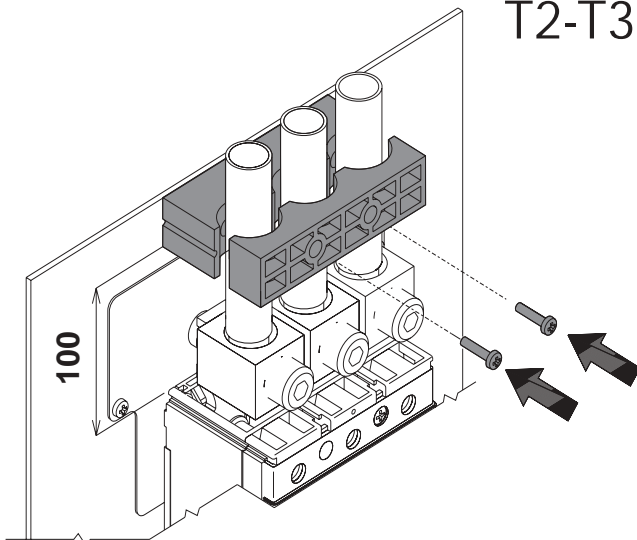

- **Attenzione:** fissare i cavi al quadro prima di serrare i morsetti; setti di ancoraggio a cura del cliente.
- **Important note:** fit the cables to the switchboard before tightening the terminals; Anchor plates to be supplied by the customer.
- **Achtung:** vor dem Festziehen der Klemmen die Kabel an der Schaltanlage befestigen; Verankerungswände vom Kunden beizustellen.
- **Attention:** fixer les câbles au tableau avant de serrer les bornes; secteurs d'ancrage à la charge du client.
- **Atención:** sujetar los cables al cuadro antes de apretar los bornes; placas de anclaje a cargo del cliente.

F

T2-T3



ABB

ABB SACE S.p.A.

Via Baioni, 35

24123 Bergamo

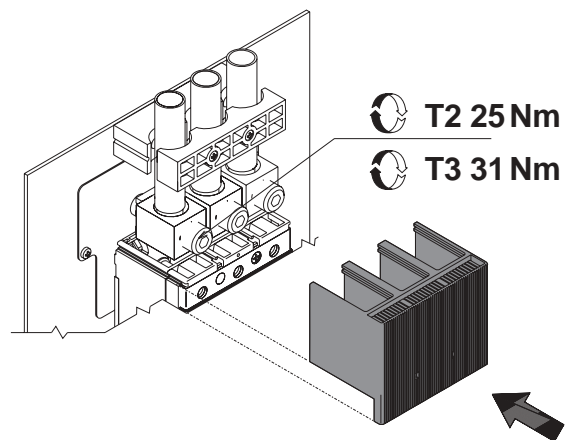
Tel.: +39 035 395.111 -Telefax: +39 035 395.306-433

<http://www.abb.com>